

Z200 PI20 Power

Instructions for installation and use - English
Heat pump
Translation of the original instructions in French

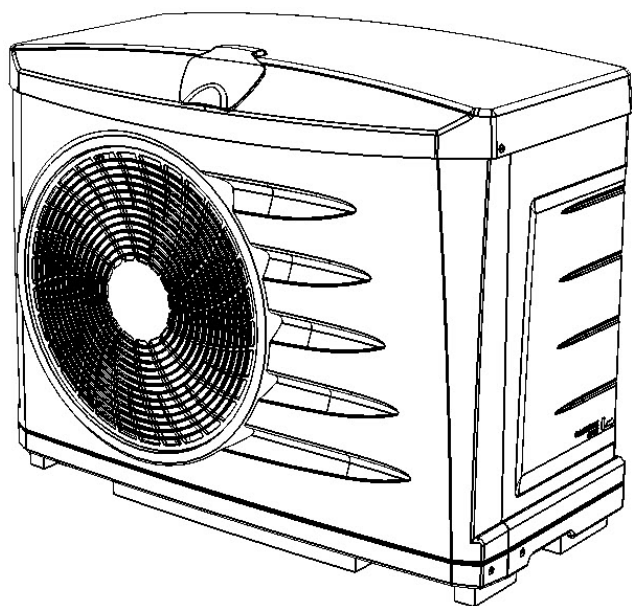



EN

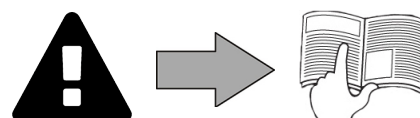



More documents on:
www.zodiac.com



⚠ WARNINGS

	This symbol shows that information is available such as the Operating Manual or Installation Manual.		This symbol shows that this appliance uses R32, a low burning velocity refrigerant.
	This symbol shows that the Operation Manual should be read carefully.		This symbol shows that a service personnel should be handling this equipment with reference to the Installation Manual.

GENERAL WARNINGS

- Failure to respect the warnings may cause serious damage to the pool equipment or cause serious injury, even death.
- Only a person qualified in the technical fields concerned (electricity, hydraulics or refrigeration) is authorised to perform any servicing or repairs to the appliance. The qualified technician working on the appliance must use/wear personal protective equipment (such as safety goggles and protective gloves, etc.) in order to reduce the risk of injury occurring when working on the appliance.  
- Before handling the machine, ensure that the power is switched off and isolated from the power supply.
- The appliance is intended to be used for pools and spas for a specific purpose; it must not be used for any purpose other than that for which it was designed.
- This appliance is not intended for use by children.
- This appliance is not intended for use by persons (including children, aged 8 years and above) with reduced physical, sensory or mental capabilities or lack of experience and knowledge, unless:
 - they have been given supervision or instruction, by a person responsible for their safety, concerning use of the appliance in a safe way by a person responsible for their safety; and
 - they clearly understand the hazards involved.
- Children should be supervised to ensure that they do not play with the appliance.
- Cleaning and similar user maintenance shall not be made by children without adult supervision.
- The appliance must be installed according to the manufacturer's instructions and in compliance with local standards. The installer is responsible for installing the appliance and for compliance with national installation regulations. Under no circumstances may the manufacturer be held liable in the event of failure to comply with applicable local installation standards.
- For any work other than the simple user maintenance described in this manual, the product should be referred to a qualified professional.
- Incorrect installation and/or use may cause serious damage to property or serious injuries (possibly causing death).
- All equipment, even postage and packing paid, travels at the risks and perils of the recipient. The latter shall issue reserves in writing on the carrier's delivery slip if damage is detected, caused during transport (confirmation to be sent to the carrier within 48 hours by registered letter). In the event that an appliance containing coolant has been turned on its side, mention your reservations in writing to the carrier.
- If the appliance suffers a malfunction, do not try to repair it yourself; instead contact a qualified technician.
- Refer to the warranty conditions for details of the permitted water balance values for operating the appliance.
- Deactivating, eliminating or by-passing any of the safety mechanisms integrated into the appliance shall automatically void the warranty, in addition to the use of spare parts manufactured by unauthorised third-party manufacturers.
- Do not spray insecticide or any other chemical (inflammable or non-inflammable) in the direction of the appliance, as this may damage the body and cause a fire.
- Do not touch the fan or moving parts and do not place any objects or your fingers

in the vicinity of the moving parts during operation of the appliance. Moving parts can cause serious injury or even death.

WARNINGS ASSOCIATED WITH ELECTRICAL APPLIANCES

- The electrical supply to the appliance must be protected by a 30 mA differential Residual Current protection Device (RCD), complying with the standards and regulations in force in the country in which it is installed.
- Do not use any extension lead when connecting the appliance; connect the appliance directly to a suitable power supply circuit.
- If a stationary appliance is not fitted with a supply cord and a plug, or with other means for disconnection from the supply mains having a contact separation in all poles that provide full disconnection under overvoltage category III conditions, the instructions shall state that means for disconnection must be incorporated in the fixed wiring in accordance with the wiring rules.
- A Suitable disconnecting means, which complies with all local and national requirements for over-voltage category III, and which disconnects all poles of the supply circuit, must be installed in the supply circuit to the appliance. Such disconnecting means is not provided with the appliance and must be provided by the installation professional.
- Before carrying out any operations, check that:
 - The voltage indicated on the appliance information plate corresponds to the mains voltage.
 - The power grid is adapted to the power requirements of the appliance, and is grounded.
 - The plug (where applicable) is suitable for the socket.
- In the event of anormal operation or the release of unusual odours from the appliance, turn it off immediately, unplug it from its power supply and contact a professional.
- Before any access to the appliance for service or maintenance, ensure that it is switched off and completely disconnected from the power supply. Furthermore, in addition to confirming that the heating priority (where applicable) is deactivated, ensure that any other equipment or accessories connected to the appliance are also disconnected from the power supply circuit.
- Do not disconnect and reconnect the appliance to the power supply when in operation.
- Do not pull on the power cord to disconnect it from the power supply.
- If the power cord is damaged, it must be replaced by the manufacturer, its technician or a qualified person to guarantee safety.
- Do not perform maintenance or servicing operations on the appliance with wet hands or if the appliance is wet.
- Before connecting the appliance to the source of supply, ensure that the terminal block or supply socket to which the appliance will be connected is in good condition and is not damaged or corroded in any way.
- For any component or sub-assembly containing a battery: do not recharge or dismantle the battery, or throw it into a fire. Do not expose it to high temperatures or direct sunlight.
- In stormy weather, disconnect the appliance from the power supply to prevent it from suffering lightning damage.
- Do not immerse the appliance in water (with the exception of cleaners) or mud.

WARNINGS CONCERNING APPLIANCES CONTAINING R32 REFRIGERANT

- This device contains R32 refrigerant, a class A2L refrigerant, which is considered to be potentially flammable.
- Do not discharge R32 fluid into the atmosphere. These are fluorinated greenhouse effect gases, covered by the Kyoto Protocol, with a Global Warming Potential (GWP) = 675 (EU Regulation No. 517/2014).
- In order to comply with relevant environmental and installations standards and regulations such as, but not limited to, French decree No. 2015-1790 and/or the EU Regulation EU 517/2014, the cooling circuit must be checked for leakage at least once a year. This operation must be carried out by a certified cooling appliance specialist.

- The device must be stored in a ventilated place away from all sources of fire.
- Install the unit outdoors. Do not install the unit indoors or in an enclosed, non-ventilated area outdoors.
- Do not use means to accelerate the defrosting process or to clean, other than those recommended by the manufacturer.
- The appliance shall be stored in a room without continuously operating ignition sources (for example: open flames, an operating gas appliance or an operating electric heater).
- Do not pierce or burn.
- Be aware that R32 refrigerants may not contain an odour.

INSTALLATION AND MAINTENANCE

- The appliance may not be installed close to combustible materials, or an air duct inlet of an adjacent building.
- With some appliances, it is essential to fit protection grids if the unit is installed in an area with uncontrolled access.
- During installation, troubleshooting and maintenance, pipes may not be used as steps: the pipe could break under the weight, spilling coolant and possibly causing serious burns.
- When servicing the appliance, the composition and state of the heat transfer fluid must be checked, as well as the absence of any traces of coolant.
- During the appliance's annual sealing test in accordance with applicable legislation, the high and low pressure switches must be checked to ensure that they are securely fastened to the cooling circuit and that they cut off the electrical circuit when tripped.
- During maintenance work, ensure there are no traces of corrosion or oil around the cooling components.
- Before beginning work on the cooling circuit, stop the appliance and wait for a few minutes before fitting the temperature and pressure sensors. Some elements such as the compressor and piping may reach temperatures in excess of 100°C and high pressures with the consequent risk of severe burns.

Area check

- Prior to beginning work on systems containing flammable refrigerants, safety checks are necessary to ensure that the risk of ignition is minimised.

Work procedure

- Work shall be undertaken under a controlled procedure so as to minimise the risk of a flammable gas or vapour being present while the work is being performed.

General work area

- All maintenance staff and others working in the local area shall be instructed on the nature of work being carried out. Work in confined spaces shall be avoided.

Check for the presence of refrigerant

- The area shall be checked with an appropriate refrigerant detector prior to and during work, to ensure the technician is aware of potentially toxic or flammable atmospheres. Ensure that the leak detection equipment being used is suitable for use with all applicable refrigerants, i.e. non-sparking, adequately sealed or intrinsically safe.

Check for the presence of a fire extinguisher

- If any work involving heat is to be conducted on the refrigerating equipment or any associated parts, appropriate fire extinguishing equipment shall be available to hand. Have a dry powder or CO₂ fire extinguisher adjacent to the charging area.

No source of ignition

- No person carrying out work in relation to a refrigerating system which involves exposing any pipe work shall use any sources of ignition in such a manner that it may lead to the risk of fire or explosion. All possible ignition sources, including cigarette smoking, should be kept sufficiently far away from the site of installation, repairing, removing and disposal, during which refrigerant can possibly be released to the surrounding space. Prior to work taking place, the area around the equipment is to be surveyed to make sure that there are no flammable hazards or ignition risks. «No Smoking» signs shall be displayed.

Area ventilation

- Prior to penetrating the unit in any way to perform any required service, ensure that the area is open and adequately ventilated. Proper ventilation, to allow for safe dispersion of any refrigerant which may be inadvertently released to the atmosphere, should be maintained while service is being performed on the unit.

Refrigeration equipment check

- The manufacturer's service and maintenance guidelines must be followed at all times. When replacing any electrical components, be sure to use only components which are of the same type and rating and which are recommended/approved by the manufacturer. If in doubt, consult the manufacturer's technical department for assistance.
- The following checks shall be applied to installations using flammable refrigerants:
 - if an indirect refrigerating circuit is being used, the secondary circuit shall be checked for the presence of refrigerant;
 - Marking to the equipment continues to be visible and legible. Markings and signs that are illegible shall be corrected;
 - refrigerating pipe or components are installed in a position where they are unlikely to be exposed to any substance which may corrode refrigerant containing components, unless the components are constructed of materials which are inherently resistant to being corroded or are suitably protected against being so corroded.

Electrical component check

- Repair and maintenance to electrical components shall include initial safety checks and component inspection procedures. If a fault exists that could compromise safety, then no electrical supply shall be connected to the circuit until it is satisfactorily dealt with. If the fault cannot be corrected immediately but it is necessary to continue operation, an adequate temporary solution shall be used. This shall be reported to the owner of the equipment so all parties are advised.
- Initial safety checks shall include:
 - that capacitors are discharged: this shall be done in a safe manner to avoid possibility of sparking;
 - that no live electrical components and wiring are exposed while charging, recovering or purging the system;
 - that there is continuity of earth bonding.

Repair of insulated components

- During repairs to sealed components, all electrical supplies shall be disconnected from the equipment being worked upon prior to any removal of sealed covers, etc. If it is absolutely necessary to have an electrical supply to equipment during servicing, then a permanently operating form of leak detection shall be located at the most critical point to warn of a potentially hazardous situation.
- Particular attention shall be paid to the following to ensure that by working on electrical components, the casing is not altered in such a way that the level of protection is affected. This shall include damage to cables, excessive number of connections, terminals not made to original specification, damage to seals, incorrect fitting of glands, etc.
- Ensure that the apparatus is mounted securely.
- Ensure that seals or sealing materials have not degraded to the point that they no longer serve the purpose of preventing the ingress of flammable atmospheres. Replacement parts shall be in accordance with the manufacturer's specifications.

Repair of intrinsically safe components

- Do not apply any permanent inductive or capacitance loads to the circuit without ensuring that this will not exceed the permissible voltage and current permitted for the equipment in use.
- Intrinsically safe components are the only types that can be worked on while live in the presence of a flammable atmosphere. The test apparatus shall be at the correct rating.
- Replace components only with parts specified by the manufacturer. Other parts may result in the ignition of refrigerant in the atmosphere from a leak.

Wiring

- Check that cabling will not be subject to wear, corrosion, excessive pressure, vibration, sharp edges or any other adverse environmental effects. The check shall also take into account the effects of aging or continual vibration from sources such as compressors or fans.

Detection of flammable refrigerant

- Under no circumstances shall potential sources of ignition be used in the searching for or detection of refrigerant leaks. A halide torch (or any other detector using a naked flame) shall not be used.
- The following leak detection methods are deemed acceptable for all refrigerant systems.
- Electronic leak detectors may be used to detect refrigerant leaks but, in the case of flammable refrigerants, the sensitivity may not be adequate, or may need re-calibration. (Detection equipment shall be calibrated in a refrigerant-free area.) Ensure that the detector is not a potential source of ignition and is suitable for the refrigerant used. Leak detection equipment shall be set at a percentage of the LFL of the refrigerant and shall be calibrated to the refrigerant employed, and the appropriate percentage of gas (25% maximum) is confirmed.
- Leak detection fluids are also suitable for use with most refrigerants but the use of detergents containing chlorine shall be avoided as the chlorine may react with the refrigerant and corrode the copper pipe-work.
- If a leak is suspected, all naked flames shall be removed/extinguished.
- If a leakage of refrigerant is found which requires brazing, all of the refrigerant shall be recovered from the system, or isolated (by means of shut off valves) in a part of the system remote from the leak.

Removal and discharge

- When breaking into the refrigerant circuit to make repairs - or for any other purpose - conventional procedures shall be used. However, for flammable refrigerants it is important that best practice is followed since flammability is a consideration. The following procedure shall be adhered to:
 - remove refrigerant;
 - purge the circuit with inert gas (optional for A2L);
 - evacuate (optional for A2L);
 - purge with inert gas (optional for A2L);
 - open the circuit by cutting or brazing.
- The refrigerant charge shall be recovered into the correct recovery cylinders. For appliances containing flammable refrigerants other than A2L refrigerants, the system shall be purged with oxygen-free nitrogen to render the appliance safe for flammable refrigerants. This process may need to be repeated several times. Compressed air or oxygen shall not be used for purging refrigerant systems.

Loading procedures

- Ensure that the outlet for the vacuum pump is not close to any potential ignition sources and that ventilation is available.
- In addition to conventional charging procedures, the following requirements shall be followed.
 - Ensure that contamination of different refrigerants does not occur when using charging equipment. Hoses or lines shall be as short as possible to minimise the amount of refrigerant contained in them.
 - Cylinders shall be kept in an appropriate position according to the instructions.
 - Ensure that the refrigerating system is earthed prior to charging the system with refrigerant.
 - Label the system when charging is complete (if not already).
 - Extreme care shall be taken not to overfill the refrigerating system.
- Prior to recharging the system, it shall be pressure-tested with the appropriate purging gas. The system shall be leak-tested on completion of charging but prior to commissioning. A follow up leak test shall be carried out prior to leaving the site.

Dismantling

- Before carrying out this procedure, it is essential that the technician is completely

familiar with the equipment and all its detail. It is recommended good practice that all refrigerants are recovered safely. Prior to the task being carried out, an oil and refrigerant sample shall be taken in case analysis is required prior to re-use of recovered refrigerant. It is essential that electrical power is available before the task is commenced.

1. Become familiar with the equipment and its operation.
2. Isolate system electrically.
3. Before attempting the procedure, ensure that:
 - mechanical handling equipment is available. if required. for handling refrigerant cylinders;
 - all personal protective equipment is available and being used correctly;
 - the recovery process is supervised at all times by a competent person;
 - recovery equipment and cylinders conform to the appropriate standards.
4. Pump down refrigerant system, if possible.
5. If a vacuum is not possible, make a manifold so that refrigerant can be removed from various parts of the system
6. Make sure that cylinder is situated on the scales before recovery takes place.
7. Start the recovery machine and operate in accordance with instructions.
8. Do not overfill cylinders (no more than 80 % volume liquid charge).
9. Do not exceed the maximum working pressure of the cylinder, even temporarily.
10. When the cylinders have been filled correctly and the process completed, make sure that the cylinders and the equipment are removed from site promptly and all isolation valves on the equipment are closed off.
11. Recovered refrigerant shall not be charged into another refrigerating system unless it has been cleaned and checked.

TROUBLESHOOTING

- All soldering work must be carried out by a someone qualified to do so.
- Replacement pipes must always be made of copper in compliance with standard NF EN 12735-1.
- Leak detection, pressure test:
 - never use oxygen or dry air (risk of fire or explosion)
 - use dry nitrogen or the mixture of nitrogen and coolant indicated on the information plate,
 - the test pressure for both the high and low pressure circuits must not exceed 42 bar (for R410A), 20 bar and 15 bar (for R407C) if the appliance is equipped with the optional pressure gauge.
- The high pressure circuit pipes are made of copper and have a diameter equal to or greater than 1''5/8. A certificate as indicated in §2.1 in compliance with standard NF EN 10204 will be requested from the supplier and filed with the facility's technical documentation.
- Technical data relative to the safety requirements of the various applicable directives are indicated on the information plate. All this information must be recorded in the appliance's installation manual, which must be kept in the its technical file: model, code, serial number, maximum and minimum OT, OP, year of manufacture, CE marking, manufacturer's address, coolant and weight, electrical parameters, thermo-dynamic and acoustic performance.

LABELLING

- Equipment shall be labelled stating that it has been decommissioned and emptied of refrigerant.
- The label shall be dated and signed.
- For appliances containing flammable refrigerants, ensure that there are labels on the equipment stating the equipment contains flammable refrigerant.

RECOVERING

- When removing refrigerant from a system. either for servicing or decommissioning, it is recommended good practice that all refrigerants are removed safely.
- When transferring refrigerant into cylinders, ensure that only appropriate refrigerant recovery cylinders are employed. Ensure that the correct number of cylinders for holding the total system charge is available. All cylinders to be used

are designated for the recovered refrigerant and labelled for that refrigerant (i.e. special cylinders for the recovery of refrigerant). Cylinders shall be complete with pressure-relief valve and associated shut-off valves in good working order. Empty recovery cylinders are evacuated and, if possible, cooled before recovery occurs.

- The recovery equipment shall be in good working order with a set of instructions concerning the equipment that is at hand and shall be suitable for the recovery of all appropriate refrigerants including, when applicable, flammable refrigerants. In addition, a set of calibrated weighing scales shall be available and in good working order. Hoses shall be complete with leak-free disconnect couplings and in good condition. Before using the recovery machine, check that it is in satisfactory working order, has been properly maintained and that any associated electrical components are sealed to prevent ignition in the event of a refrigerant release. Consult manufacturer if in doubt.
- The recovered refrigerant shall be returned to the refrigerant supplier in the correct recovery cylinder, and the relevant waste transfer note arranged. Do not mix refrigerants in recovery units and especially not in cylinders.
- If compressors or compressor oils are to be removed, ensure that they have been evacuated to an acceptable level to make certain that flammable refrigerant does not remain within the lubricant. The evacuation process shall be carried out prior to returning the compressor to the suppliers. Only electric heating to the compressor body shall be employed to accelerate this process. When all is drained from a system, it shall be carried out safely.

EN

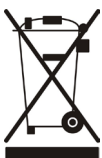





RECYCLING

This symbol means that your appliance must not be thrown into a normal bin. It will be selectively collected for the purpose of reuse, recycling or transformation. Any substances it may contain which are potentially dangerous to the environment shall be eliminated or neutralised. Request information on recycling procedures from your retailer.



- Before you do anything with the device, it is vital that you read this installation and user manual, as well as the “Warranty” booklet delivered with the device. Failure to do so may result in material damage or serious or fatal injury and will invalidate the warranty.
- Keep and pass on these documents for later consultation during the device’s life time.
- It is prohibited to distribute or modify this document in any way without authorisation from Zodiac®.
- Zodiac® is constantly developing its products to improve their quality; therefore, the information contained in this document may be modified without notice.

CONTENTS

	1 Specifications	9
1.1 Description		9
1.2 Technical specifications		10
1.3 Dimensions and marking		11
	2 Installation	12
2.1 Selecting the location		12
2.2 Hydraulic connections		13
2.3 Electricity supply connections		14
2.4 Option connection		15
	3 Use	16
3.1 Operating principle		16
3.2 User interface presentation		16
3.3 Operating		17
3.4 User functions		18
	4 Maintenance	19
4.1 Winterizing		19
4.2 Maintenance		19
	5 Troubleshooting	20
5.1 Device behaviour		20
5.2 Error code display		21
5.3 Wiring diagrams		22



Tip: to make it easier to contact your reseller

- Write down your reseller's contact details to help you find them more easily and fill in the "product" information on the back of the manual; your reseller will ask you for this information.



1 Specifications

1.1 Description

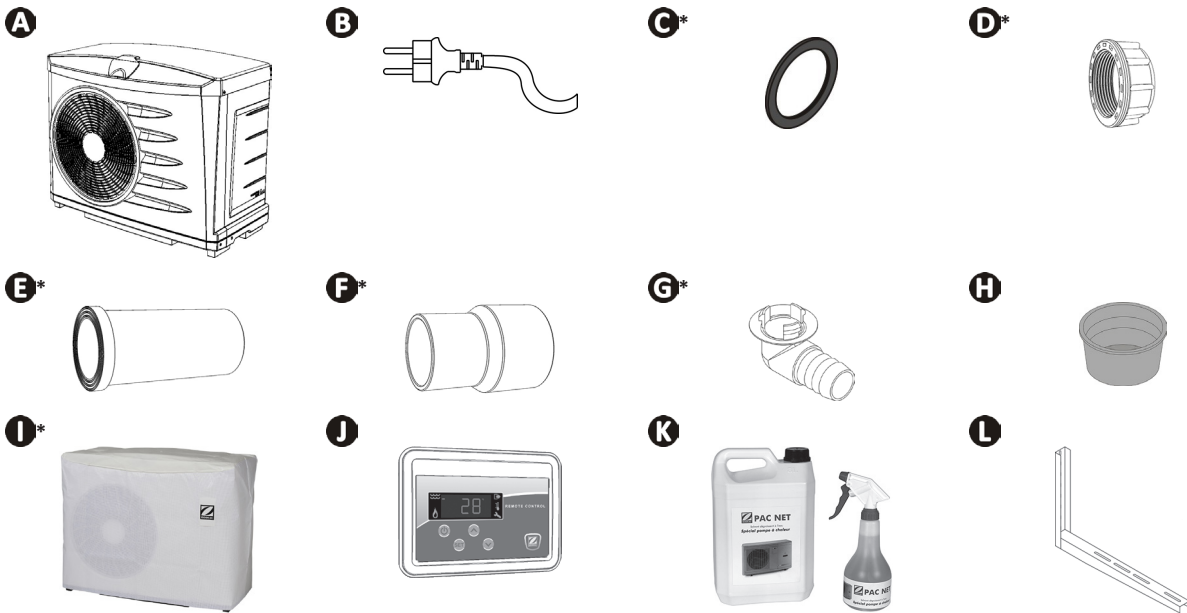

*In the polystyrene cap above the heat pump

A		Z200	PI20	Power
B	Supply cable			✓ with plug except 11M
C	Joint (x2)	✓	✓	✓
D	Screw-in connector (x2)	✓	✓	✓
E	Ø40 adaptation (x2)	✓	✓	✓
F	Ø50 reduction (x2)	✓	✓	✓
G	Condensation evacuation kit (Ø15)	✓	✓	+
H	Winterizing cap (x2)	✓	✓	✓
I	Winterizing cover	✓	✓	+
	Heating priority	✓	✓	Not compatible
J	Remote control	+	+	Not compatible
K	PAC NET (cleaning product)	+	+	+
L	Wall mounting kit	+	+	+

✓: supplied

+: available as an accessory

EN

1.2 I Technical specifications

		Standards				Defrost			
Z200		M2	M3	M4	M5	MD2	MD3	MD4	MD5
PI20		PI2021	PI2031	PI2041	PI2051	PI2021D	PI2031D	PI2041D	PI2051D
Power		5M	7M	9M	11M				
Operating temperature range	air	5 to 32°C				- 5 to 32°C			
	water	up to 32°C							
Operating power*	kW	4.5	6.4	7.9	9.7	4.8	7	8.1	10.1
Voltage	230V-50Hz								
Defrosting by forced air circulation		X	X	X	X				
Defrosting by cycle inversion						X	X	X	X
Acceptable variation in voltage	-10%, +7% (during operation)								
Pollution class**	I								
Pollution degree**	2								
Overvoltage category**	II								
Nominal absorbed intensity	A	4.5	6.3	7.9	11.2	4.5	6.3	7.9	11.2
Maximum absorbed intensity	A	5.2	7.6	10.2	13.4	5.2	7.6	10.2	13.4
Minimum cable section***	mm ²	3x2,5							
		3G2,5							
Proof pressure	bar	6							
Service pressure	bar	1.5							
Max. Discharge/Suction Pressure	bar	42/1.2							
Max. high-pressure/low pressure side pressure	bar	42/1.2							
Head loss	mCE	1	1.5		1		1.5		
Minimum optimum water flow rate	m ³ /h	4							
Maximum water flow	m ³ /h	10							
Refrigerant type	R32								
Refrigerant charge	kg	0.68	0.85	0.9	1.1	0.68	0.8	0.9	1.1
Weight	kg	40	45	50	53	40	45	50	53

The appliances have an Ingress Protection (IP) rating of IPX4 or better. Please refer to the marking indicating the IP-rating on your particular product.

* Performance: air 15 °C / water 26 °C / humid. 70%.

** These characteristics have been determined from the requirements defined in IEC/EN 60335 and IEC/EN 60035-2-40 for the safety of household and similar electrical appliances.

*** Values provided for information purposes for a maximum length of 20 metres (calculation base: NFC15-100), must be checked and adapted to the installation conditions and standards of the installation country.

1.3 I Dimensions and marking

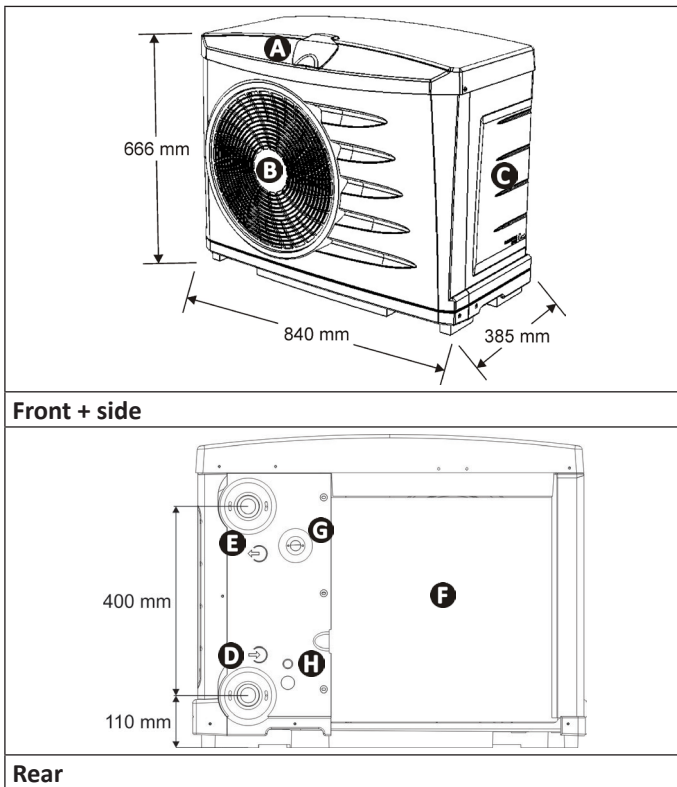

A: Protection valve and user interface

B: Ventilator

C: Technical access door

D: Pool water intake

E: Pool water output

F: Evaporator

G: Grommet for heating priority cable run*

H: Location for drilling for remote control cable run*

*depending on the model

EN



2 Installation

2.1 I Selecting the location



- When installed with and protected by an appropriate Residual Current Device (RCD) having a maximum trip current rating of 30mA, the appliance must be installed at 2 metres, minimum, from the surrounding edge of the pool.
- If an appropriate RCD is not installed with the appliance, the appliance must be installed at a minimum distance of 3.5 metres from the edge of the pool.
- Do not lift the device by the body; use its base.

- Install the device outdoors; provide free space around it (see § “2.2 I Hydraulic connections”).
- Place the device on its anti-vibration studs (integrated under its base) on a stable, solid and level surface,
- This surface must be able to bear the weight of the device (in particular in the case of installation on a roof, a balcony or any other support).
- The device may be secured to the ground using the holes in the base of the device or with rails (not supplied). A drilling scale is available on the back of the packaging carton.

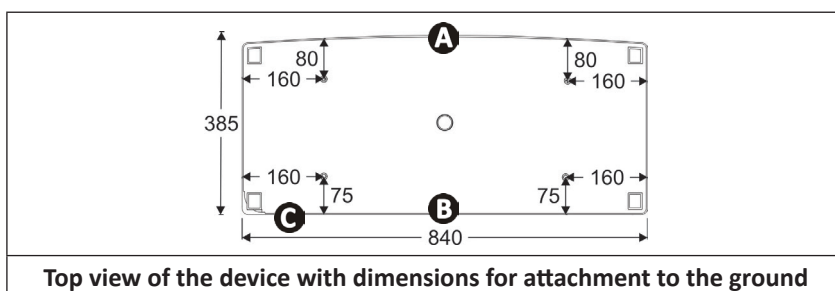

The device must not be installed:



- In a closed and unventilated room
- In a location subject to high winds,
- With the blowing towards a permanent or temporary obstacle (window, wall, hedge, awning, etc.) less than 3 metres away,
- Within range of water or mud jets, sprays or run-off (take the effect of the wind into account),
- Near a heat source or flammable gas,
- Near high frequency equipment,
- In a location where it would be subject to snow build-up,
- In a location where it might be flooded by the condensation produced by the device when operating.

Tips: reduce any noise annoyance from your heat pump



- Do not install it under or towards a window.
- Do not tilt it towards your neighbours.
- Install it in a clear space (the sound waves are reflected on surfaces).
- Install an acoustic screen around the heat pump, respecting the distances.
- Install the anti-vibration studs under the heat pump and replace them regularly.
- Install 50cm of flexible PVC pipe at the heat pump water input and output (stops vibrations).

2.2 I Hydraulic connections

- The device will be connected with a $\varnothing 40$ or $\varnothing 50$ PVC pipe, using the connectors supplied (see § “1.1 I Description”), to the pool's filtration circuit, after the filter and before the water treatment.
- Respect the direction of hydraulic connection ( = input and  = output).
- A by-pass must be installed to make it easier to work on the device.

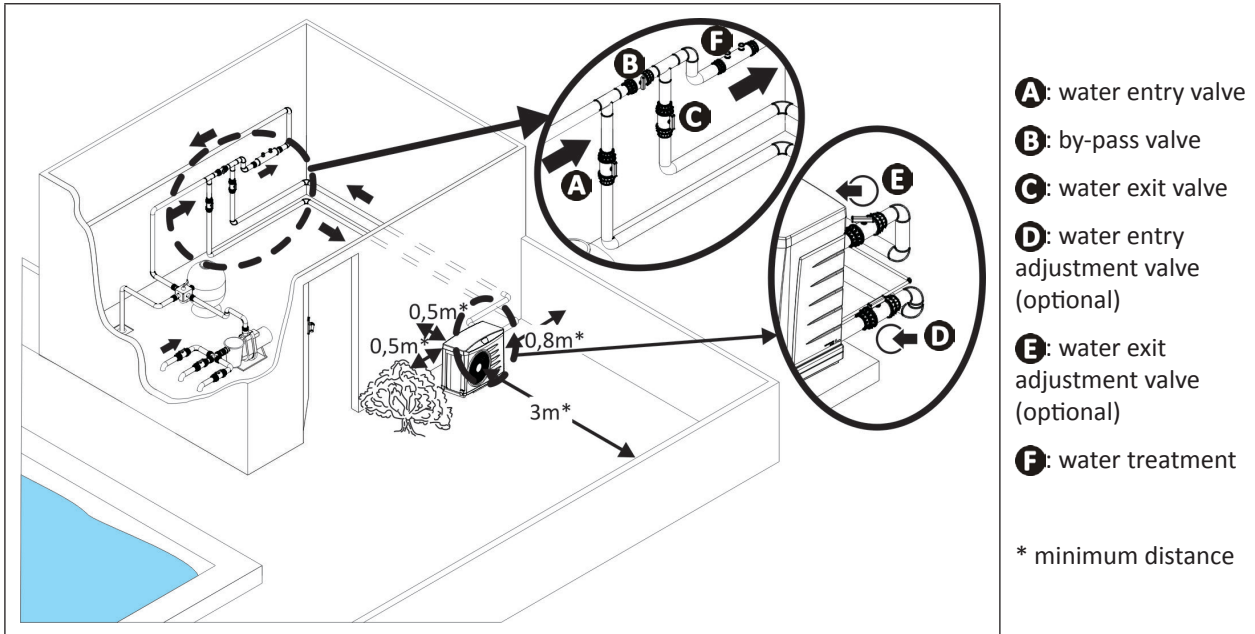

- To evacuate the condensation, fit a $\varnothing 15$ pipe on the grooved elbow to be mounted under the device base (supplied according to model, see § “1.1 I Description”).



Tip: condensation drainage

Caution, several litres of water must be drained from your device each day. We strongly recommend connecting the drainage to the sewers

2.3 I Electricity supply connections



- Before any work inside the device, you must cut the electricity supply as there is a risk of electric shock which may cause material damage, serious injury or even death.
- Incorrectly tightened terminals may cause the terminal unit to heat up and invalidate the warranty.
- Only a qualified and experienced technician is authorised to carry out cabling in the equipment or to replace the supply cable.

- The heat pump's electrical supply must be provided through a protection and circuit breaking device (not supplied) complying with the standards and regulations in force in the country where it is installed,
- The device is provided for connection to a general power supply with a TT and TN.S neutral regime.
- Electrical protection: by circuit breaker (D curve) (for calibre, see § "1.2 I Technical specifications"), with a 30 mA dedicated differential circuit breaker (circuit breaker or switch) at the head of the line.
- The electricity supply must correspond to the voltage indicated on the device's information plate.
- The electricity supply cable must be insulated against any cutting or hot elements that may damage or crush it.
- The equipment must be connected to an earth socket.
- The electrical connection lines must be fixed.
- Use the gland to pass the supply cable into the device.
- Used the supply cable (RO2V type) adapted for outdoor or buried use (or run the cable into a protection duct).
- We recommend burying the cable at a depth of 50 cl (85 cm under a road or path) in an electrical duct (red ribbed).
- If this buried cable meets another cable or pipe (gas, water, etc.), there must be more than 20 cm between them.

Depending on the model, there are 2 ways to connect:



Device not equipped with a cable (Z200, PI20 and Power 11M models)

- Connect the supply cable to the connection terminal unit inside the heat pump.

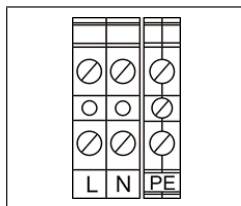

L: live

N: neutral

PE: earth

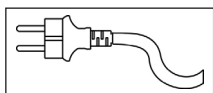

Device equipped with a cable with plug (Power models 5M, 7M or 9M)

- Check that the supply cable is firmly attached to the connection terminal.
- All use of an extension cord or multisocket connection is prohibited.
- If the supply cable is not long enough, contact a qualified technician.
- Connect the supply cable delivered with the appliance to a 16A socket, according to the country's applicable standards and regulations.

➤ 2.4 | Option connection

2.4.1 "Heating priority" option (depending on model)

- This function allows the unit to start the filtration (in 5 minutes cycle every 220 minutes) to detect the water temperature and thus switch on the filtration + heating unit to maintain this temperature at a constant value. It is said that the filtration pump is slaved to the heating system. Filtration is maintained or put into operation if the pool temperature is below the required temperature.
- For the connection, connect the filtration timer to terminals 1 and 2 and add a shunt between terminals 3 and 4.

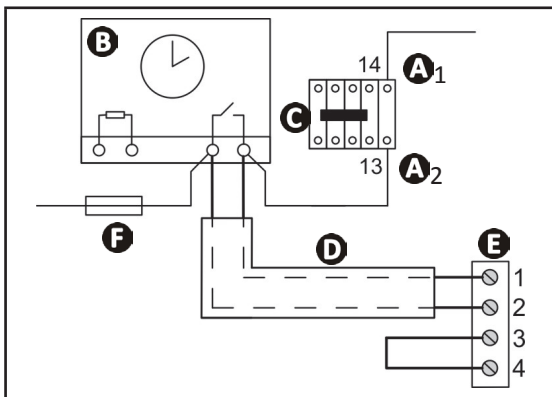

- **A1- A2** : power for the filtration pump power contactor coil
- **B**: filtration timer
- **C**: power contactor (tripolar or bipolar) for the filtration system pump motor
- **D**: separate cable for the "heating priority" function
- **E**: heat pump terminal (see wiring diagram § "5.3 | Wiring diagram")
- **F**: fuse

EN

- Modification of the time between 2 filtration operations (value in number of minutes):
 - press **⏻** and **SET** or **OK** at the same time for 3 seconds: **SEL** appears,
 - press **▲** until the **POI** parameter appears, then press **SET** or **OK** to change the parameter using the **▲** and **▼** keys.
 - Once the value has been modified, press **SET** or **OK** to confirm,
 - press **⏻** to exit the menu.

2.4.2 "Remote control" option (depending on model)

- This option enables the device's user interface to be duplicated to enable the device to be controlled by remote. To do so, use the remote control kit available as an accessory.
- For the connection, consult the manual supplied with the kit.



3 Use

3.1 I Operating principle

Your heat pump uses the calories (heat) in the air to heat up your pool's water. The process to heat your pool's water to the temperature you want may take a few days as it depends on the weather conditions, your heat pump's power and the difference between the water temperature and the temperature you want.

The heat pump is ideal for maintaining temperature.

The warmer and damper the air, the better your heat pump will perform. The outdoor parameters for optimum operation are an air temperature of 27°C, a water temperature of 27°C and 80% hygrometry.

Tips: improve your pool's temperature rise and maintenance



- Anticipate the commissioning of your pool far enough in advance before you use it.
- For the temperature rise, set the filtration pump to continuous operation (24/24).
- To maintain the temperature throughout the season, switch to "automatic" circulation equal to at least the water temperature divided by two (the longer this time will be, the more the heat pump will have an operating range sufficient to heat).
- Cover the basin with a sheet (bubble canopy, canvas, etc.) to prevent heat loss.
- Take advantage of a period with mild outdoor temperatures (on average > 10°C at night); your heat pump will be even more effective if it runs during the warmest hours of the day.
- Keep the evaporator clean (see § "4.2 I Maintenance").
- Set the temperature you want and let the heat pump run (adjusting the setpoint to maximum will not heat the water more quickly).
- Connect the "Heating priority"; the filtration pump and heat pump operating time will be set according to requirements.

3.2 User interface presentation

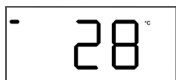

Display screen (default: setpoint temperature)



"On/off" button

SET

Pool water temperature reading or parameter setting button



Value setting buttons

Symbol	Designation	Fixed	Flashing	Off
	Water flow	Water flow ok	Water flow too low or missing	/
	Heating	Active	starting	Inactive
	Ambient air temperature	Sufficient	Insufficient	/
	Priority heating connected	Priority heating connected and heating request	Priority heating connected but no heating request	Priority heating not connected
	Fault	Fault in progress, see § "5.2 I Error code display"	Heating priority connected, heating requested but water flow too low or missing	No fault

▶ 3.3 I Operating

- Check that there are no tools or other foreign objects in the machine.
- The panel that provides access to the technical section must be put in place.
- Set the valves as follows: valve B wide open, valves A, C, D and E closed

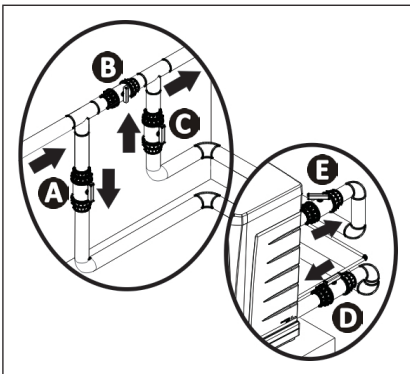

- A**: water entry valve
- B**: by-pass valve
- C**: water exit valve
- D**: water entry adjustment valve (optional)
- E**: water exit adjustment valve (optional)

EN



• An incorrect by-pass setting may cause the heat pump to malfunction.

- Check that the hydraulic corrections are correctly tightened and that there are no leaks.
- Check that the device is fully stable.
- Set the water circulation running.
- Close valve B gradually so that the filter pressure is increased by 150g (0.150 bars).
- Open valves A, C and D fully then valve E by half (the air which has built up in the heat pump condenser and the filtration circuit will bleed out). If valves D and E are not present, open valve A wide and close valve C by half.
- Connect the power supply to the heat pump:

704

program version number (different according to model)

Screen saver



Press and hold  for 2 seconds

888

Splash screen

28

Temperature setpoint

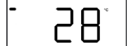
- Device starts after a timer of up to 5 minutes,
- Set the temperature you want ("setpoint" temperature) by pressing  or .
- After the steps to start up your heat pump, stop the water circulation temporarily to check that your device stops after a few seconds (by activating the flow controller):  the water flow light must flash.

Information: light water flow



➤ 3.4 I User functions

3.4.1 Water temperature reading

When the water is circulating through the heat pump, press **SET**:  flashes for 10 seconds then the setpoint temperature is displayed fixed.



- To read the water temperature, it is imperative that the filtration is in operation and that the water flow indicator is fixed.

3.4.2 Locking/unlocking the keyboard

Locking the keyboard

Press and hold ▲+▼ for 3 seconds

 3 seconds

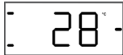

Unlocking the keyboard

Press and hold ▲+▼ for 3 seconds

 flashes for 4 seconds

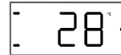



4 Maintenance

4.1 I Winterizing



- **Winterizing is vital to prevent the condenser breaking due to freezing. This is not covered by the warranty.**
- **To avoid damaging the equipment with condensation, do not fully cover it.**

- Switch off the device by pressing and holding  for 2 seconds and disconnect it or switch off the electricity supply,
- Close the water input and output valves and make sure that there is no water circulating in the heat pump,
- Drain the water from the condenser (risk of freezing) by unscrewing the water input and output connectors on the back of the heat pump,
- In the case of full winterizing for the pool (complete shutdown of the filtration system, bleed the filtration circuit or even pool drainage): tighten the two connectors by one turn to prevent any foreign bodies from getting into the condenser,
- In the case of winterizing for the heat pump only (shutdown of the heating only, the filtration keeps running): do not tighten the connectors but add 2 caps (provided) on the condenser's water inputs and outputs.
- We recommend that you put the aired winterizing micro cover on the heat pump.

EN

4.2 I Maintenance



- **It is recommended that the device be general servicing at least on a yearly basis to ensure proper operation, maintain performance levels and prevent some potential failures. These operations are carried out at the user's expense, by a technician.**

4.2.1 User maintenance

- Make sure that the filter is not blocked by any foreign bodies.
- Clean the evaporator (for location see § “1.3 I Dimensions and marking”) using a soft brush and a fresh water spray (disconnect the power cable); do not fold over the metal wings, then clean the condensation drainage pipe to remove any impurities that may be blocking it.
- Do not use a high pressure jet. Do not spray with rain water, salt water or water which is full of minerals.
- Clean the outside of the device; do not use any solvent-based products. We can provide you with a specific cleaning kit as an accessory: the PAC NET, see § “1.1 I Description”.

4.2.2 Maintenance to be carried out by a qualified technician



- **Please read the safety instructions provided in the chapter entitled “Installation and maintenance” (pages 3 to 6) before performing any of the maintenance operations described below.**

- Check that the regulation is operating correctly connected.
- Check that the condensation flows correctly when the device is operating.
- Check the safety mechanisms.
- Check the connection of the metal masses to the earth.
- Check that the electrical cables are correctly tightened and connected and that the electrical unit is clean.



5 Troubleshooting













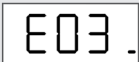

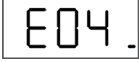
- Before you contact your reseller, please carry out these few simple checks using the following tables if a problem occurs.
- If the problem continues contact your reseller.
- : Actions reserved for a qualified technician

5.1 I Device behaviour

The device does not start heating straight away	<ul style="list-style-type: none"> • On start-up, the device remains "paused" for 5 minutes before it starts operating. • When the setpoint temperature is reached, the heat pump stops heating: the water temperature is higher than or equal to the setpoint temperature. • When the water flow rate is zero or is not enough, the heat pump stops: check that the water is circulating correctly in the heat pump and that the hydraulic connections are correct. • The heat pump stops when the outdoor temperature falls below 5 °C for standard models or -5 °C for "Defrost" models. • It may be that the heat pump has detected an operating fault (see § "5.2 I Error code display"). • If you have checked these points and the problem persists: contact your reseller.
The device is draining water	<ul style="list-style-type: none"> • Often called condensation, this water is the moisture contained in the air which condenses on contact with certain cold mechanisms in the heat pump, especially on the evaporator. The more damp the air, the more condensation your heat pump will produce (your device may drain several litres of water per day). This water is retrieved by the base of the heat pump and drained through a hole. • To check that the water is not coming from a leak in the pool circuit on the heat pump, shut down the heat pump, wait a few minutes and run the filtration pump for the water to circulate in the heat pump. If the water continues to flow through the condensation drain, there is a water leak in the heat pump; contact your reseller.
The evaporator is iced over	<ul style="list-style-type: none"> • Your heat pump will soon switch to its defrost cycle to melt the ice. • If your heat pump cannot manage to deice its evaporator, it will stop itself; this means that the outdoor temperature is too low (below 5 °C for standard models, -5 °C for "Defrost" models).
The device is not working	<ul style="list-style-type: none"> • If there is no display, check the supply voltage and the F1 fuse. • When the setpoint temperature is reached, the heat pump stops heating: the water temperature is higher than or equal to the setpoint temperature. • When the water flow rate is zero or is not enough, the heat pump stops: check that the water is circulating correctly in the heat pump. • The heat pump stops when the outdoor temperature falls below 5 °C for standard models or -5 °C for "Defrost" models. • It may be that the heat pump has detected an operating fault (see § "5.2 I Error code display").
The device is working but the water temperature does not increase	<ul style="list-style-type: none"> • It may be that the heat pump has detected an operating fault (see § "5.2 I Error code display"). • Check that the automatic filling valve is not stuck in open position; this will keep supplying cold water into the pool and will prevent the temperature from rising. • There is too much heat loss as the air is cool. Install a heat insulated cover on your pool. • The heat pump is unable to capture enough calories as its evaporator is clogged with dirt. Clean it to restore its performances (see § "4.2 I Maintenance"). • Check that the external environment is not hindering the heat pump (see § "2 Installation"). • Check that the heat pump is the right size for this pool and its environment.
The ventilator is running but the compressor stops from time to time with no error message	<ul style="list-style-type: none"> • If the outdoor temperature is low, the heat pump will perform defrost cycles. • The heat pump is unable to capture enough calories as its evaporator is clogged with dirt. Clean it to restore its performances (see § "4.2 I Maintenance").
The device trips the circuit breaker	<ul style="list-style-type: none"> • Check that the circuit breaker is correctly dimensioned and that the cable section used is the right one (see § "1.2 I Technical specifications"). • The supply voltage is too low; contact your electricity supplier.

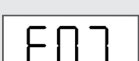
5.2 I Error code display

Display of	Possible causes	Solutions
 Air temperature sensor fault	SD2 sensor is offline or incorrectly connected	 Sensor replacement
 Deicing sensor fault	SD3 sensor is offline or incorrectly connected	 Sensor replacement
 Low-pressure fault	Low pressure fault in the cooling circuit (if fault persists after acknowledgement)	 Call an approved technician
 High-pressure fault	Air and water emulsion passed into the device	Check the pool's hydraulic circuit
	Insufficient water flow	Increase flow using by-pass, check that the pool filter is not clogged
	Water temperature too high (32 °C maximum)	Wait until the temperature falls
	Flow controller blocked	 Check the flow controller
	Water condenser scaled up or blocked	 Clean the water condenser
	Outside temperature > 30°C and measured water temperature > 30 °C	Close the bypass valve to increase the flow rate through the device
 Water temperature sensor fault	SD1 sensor is offline or incorrectly connected	 Sensor replacement
 Deicing cycle fault (>20 minutes)*	Air temperature too low	Wait until the temperature is within the operating range
	The evaporator is scaled up	Clean the evaporator (see § "4.2 I Maintenance")
	The ventilator does not work	 Replace the ventilator or the electronic board
	Wrong value provided by the air or deicing sensor	 Replace the sensor.

* Error code not active on "Defrost" models.

5.3 I Wiring diagrams

5.3.1 "Standard" models

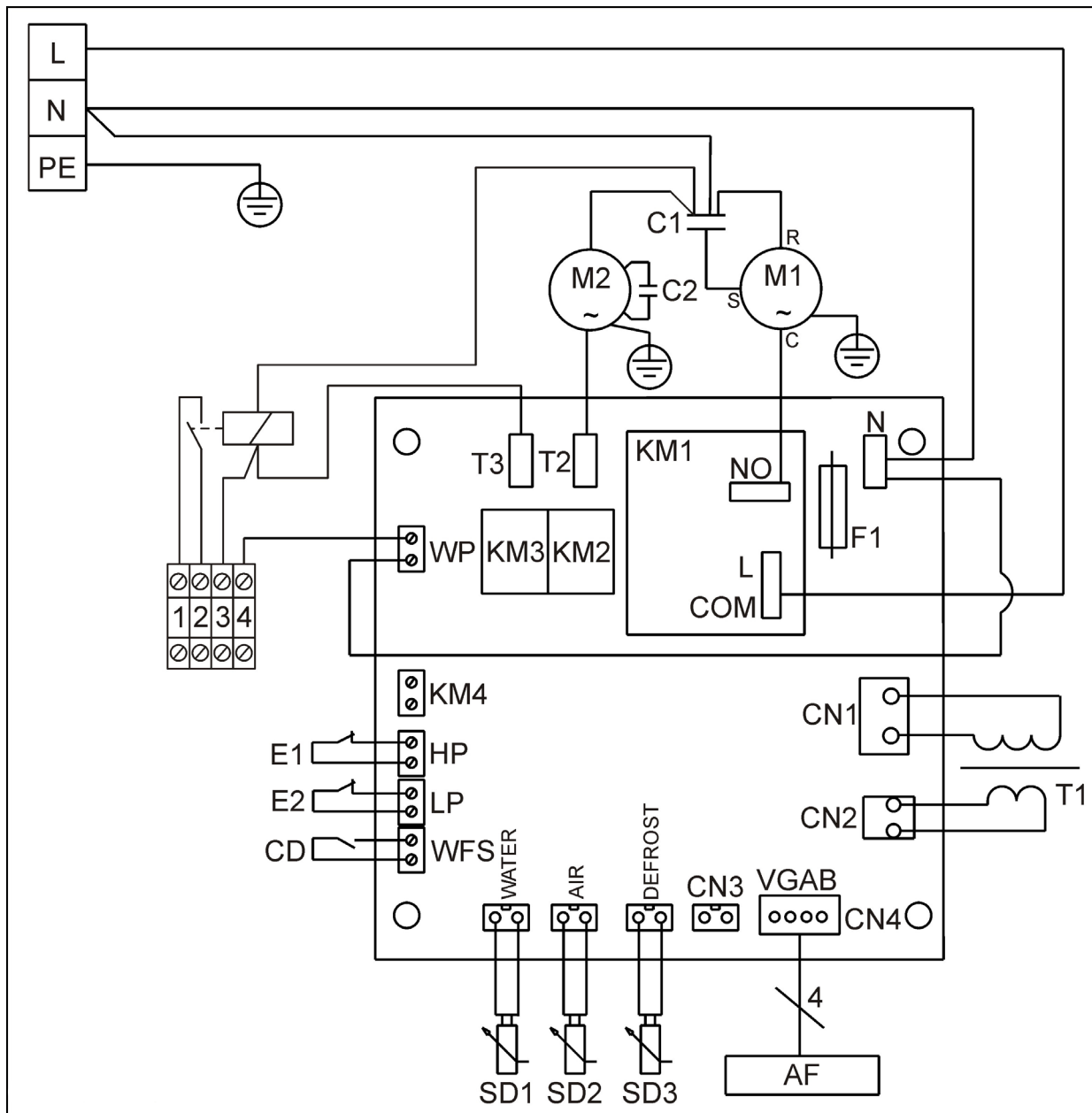

L-N-PE	230V-1N-50Hz protected power supply
AF	Digital display
⊥	Earth
C1	Compressor condenser
C2	Ventilator condenser
CD	Flow controller
E1	High pressure switch
E2	Low pressure switch
F1	Fuse
KM1	Compressor relay

KM2	Ventilator relay
KM3	Auxiliary pump relay
KM4	Complementary relay
M1	Compressor
M2	Ventilator
SD1	Water temperature sensor
SD2	Air temperature sensor
SD3	Defrost sensor
T1	Transformer
1-2-3-4	Terminal for heating priority connection

5.3.2 "Defrost" models

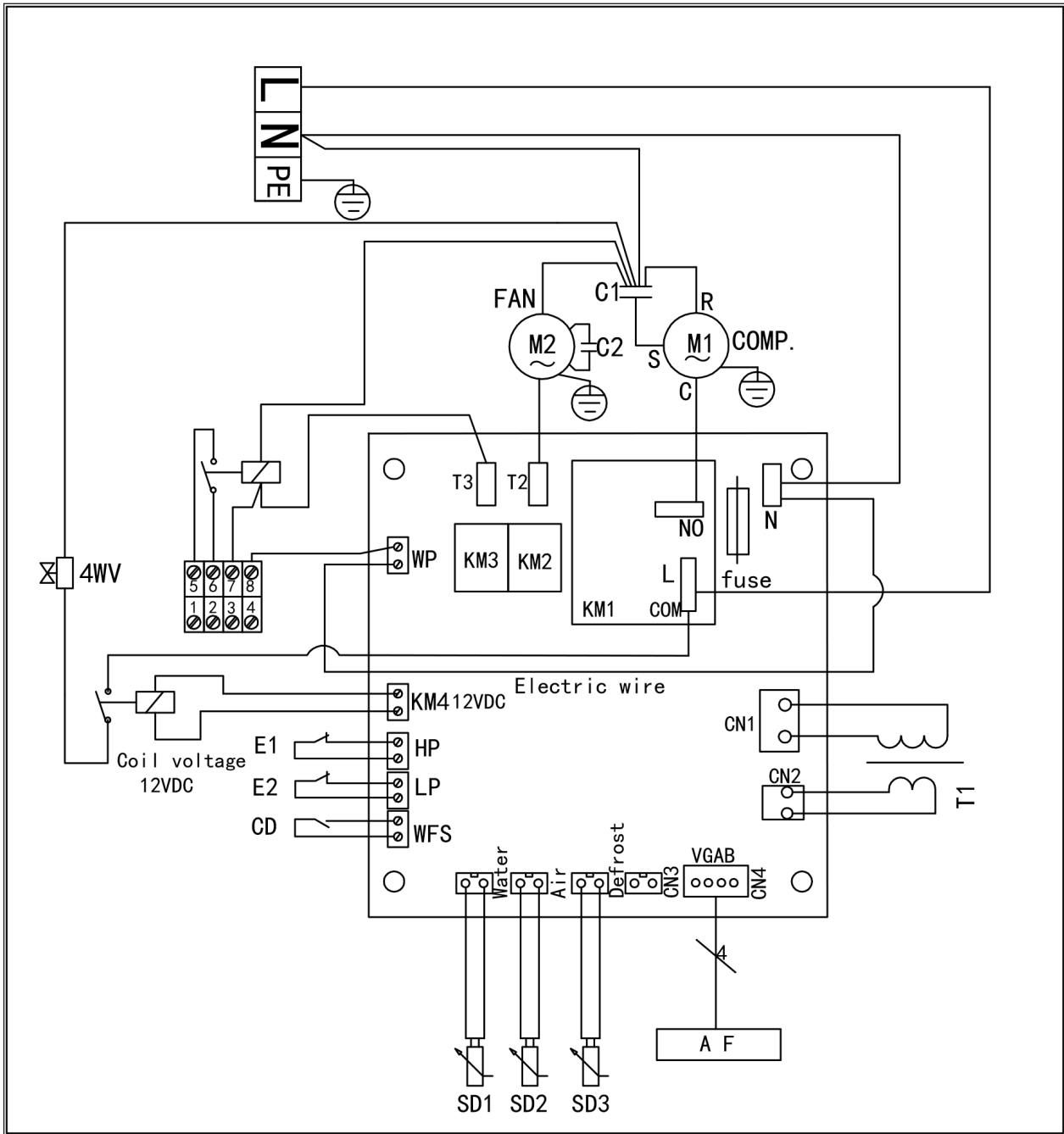

L-N-PE	230V-1N-50Hz protected power supply
AP	Digital display
⊥	Earth
C1	Compressor condenser
C2	Ventilator condenser
CD	Flow controller
HP	High pressure switch
LP	Low pressure switch
F1	Fuse
KM1	Compressor relay

KM2	Ventilator relay
KM3	Auxiliary pump relay
KM4	Complementary relay
M1	Compressor
M2	Ventilator
SD1	Water temperature sensor
SD2	Air temperature sensor
SD3	Defrost sensor
T1	Transformer
1-2-3-4	Terminal for heating priority connection

Votre revendeur
Your retailer

Modèle appareil
Appliance model

Numéro de série
Serial number

Pour plus d'informations, enregistrement produit et support client :
For more information, product registration and customer support:

www.zodiac.com

